



The Troubleshooting Resident

**TIPS ON TROUBLESHOOTING AND
PREVENTATIVE MAINTENANCE THAT CAN
SAVE YOU \$\$\$
(FOR RESIDENTS AND OWNERS PRIOR TO
SUBMITTING A WORK ORDER)**

ANNUAL HOME MAINTENANCE CHECKLIST
(A LIST OF OTHER ITEMS, NOT ALL INCLUSIVE)



Garbage Disposal



HOW
TO
FIX A

HUMMING GARBAGE DISPOSAL

If these steps do not correct the issue, please submit a work order in your GRG Resident Portal.



Ground Fault Circuit Interrupt (GFCI)

-If there is loss of electricity in any part of the home, the GFCI may have tripped.

- A GFCI may be located at any electrical outlet location, but are generally installed in the kitchen/bathrooms/garage.

-You will want to check these throughout the home, sometimes they can be wired into other outlets away from bathrooms/kitchen/garage causing other outlets to lose power in other rooms.

(Garage GFCI's are often connected to all exterior outlets)

- To RESET, you must push the button switch marked "RESET". If this action DOES NOT correct the problem then you may have a circuit breaker tripped. See next slide.

If these steps do not correct the issue, please submit a work order in your GRG Resident Portal.



Breaker Sub Panel

-If there is loss of electricity in any part of the home, and resetting the GFCI was not the problem, the breaker box might have tripped.

- Locate the Beaker Sub Panel, usually located in the garage on the wall.

-Open the box and see if there are any breakers tripped. (A breaker that is tripped is in the OFF or Neutral position.) You must fully seat the switch in the OFF position before resetting the breaker to the ON position. If not, it may not reset until you do so.



-If the breaker continues to trip or does not reset, submit a work order!

***DO NOT CONTINUE TO RESET THE BREAKER, it is likely faulty!

If these steps do not correct the issue, please submit a work order in your GRG Resident Portal.



Replacing Filters

-Once you receive your new filters for your Air Conditioning and Heating system. Locate the intake vents. These could be located



on the ceilings, walls, or at the air handler in the attic or closet.



Arrows on the edge of the filter indicate

the direction that the air travels.

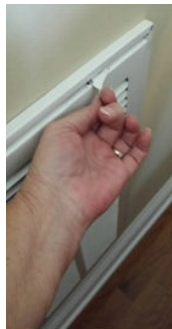

Your HVAC return air filter cover should look like this



Not like this



If these

do not correct the issue, please submit a work order in your GRG Resident Portal.

steps



Garage Door/Opener

If the garage door does not seem to respond to the remotes or wall opener, or is reversing direction, there are a couple quick fixes that generally work.

-Swap out the battery with another working remote battery to see if that is the issue, if so you will need to replace at resident's expense. See how in the [video](#).

-Garage door sensors may be misaligned, this may also cause the door to reverse and come back up or not activate at all, but you should see the garage door motor light flashing on and off. To correct this you simply have to adjust the sensors to where they are correctly hung on the metal hangar 4-6 inches off the floors facing each other. The small LED should indicate green when properly aligned.

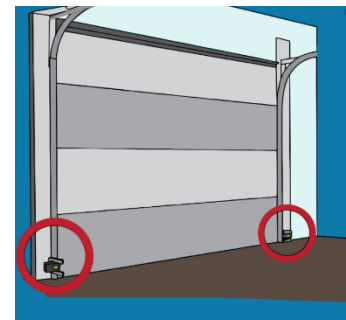

-To open the garage door manually, you must pull the manual safety release cord. This cord should have a handle attached to it. Once this is pulled the lever should point downward and you will be able to manually open and

close the door. **WARNING**, while using the door manually, it may fall if not all the way in the open position.

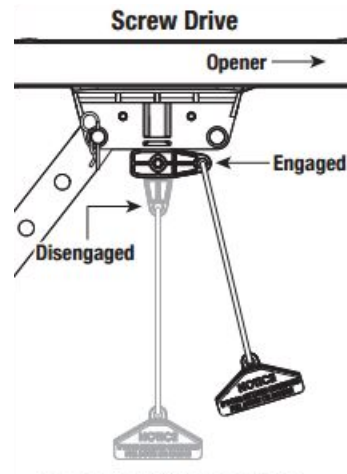

If these steps do not correct the issue, please submit a work order in your [GRG Resident Portal](#).



Water Meter/ Main cutoff

The Water meter is usually located in the strip of grass between the sidewalk and street. It could be located closer to the home in an older neighborhood. When you see the number ticking up, there IS water running to the home. When it is NOT ticking up, all water is turned off inside the home.



-If you suspect a leak or know of an obvious leak, you will need to shut off the water to prevent damage.

-This can be done several ways. If the leak doesn't stop when you turn off the faucet, then you can cut it off below the sink by turning the manual valves, which are also located behind toilets. If that does not stop the leak, see next step.



- The plumbing manifold (if the home is equipped), will be located in the garage or utility room. Use the key to close the valve that supplies water to that room. They should be

labeled. If this does not stop the leak, see next step.

-To cut off the main valve at the street, locate and open to access the meter and valve. **WATCH FOR SNAKES!**



-Then, turn the valve **CLOCKWISE 90°**. If there is not a handle, you will need an adjustable wrench.

If these steps do not correct the issue, please submit a work order in your [GRG Resident Portal](#).



Smoke Detector Battery Change

[How to change your battery on a smoke detector.](#)



If these steps do not correct the issue, please submit a work order in your [GRG Resident Portal](#).



Irrigation System

-As a reminder, it is a resident responsibility to keep up with yardwork including watering the grass. Below are some tips on how to care for your lawn.

HOW TO WATER YOUR LAWN WISELY

-There are many different Brands of irrigation control consoles, select your brand below to watch a video on how to operate your irrigation system. Systems may vary.

[Hunter](#)- Video

[Hunter Instruction Manual](#)

[Rainbird](#)-Video

[Rainbird Instruction Manual](#)

[Orbit](#)-Video

[Orbit Instruction Manual](#)

If you do not see your brand a quick Google search often gets you what you need.



Water Softener

A water softener can be a great addition to any property, however not all come equipped with one nor are all homes plumbed for one.

-If your home has a water softener and you are not sure how and when to add salt, here is a video to help you out!

[When & How to add salt to my Water Softener](#)